



IN-LINE JUNCTIONS AND MODULES CLASSE 1E - CATEGORY K1 FOR PWR POWER STATION

SECTION 9'

- Two types of sealed quick junctions:
 - MODULES for monitors, measures or low current (23 A).
 - IN-LINE JUNCTIONS for 124A power connexions.
 - EDF Standards (French Electricity Company):
 - ESE EL 82.57 - Qualification testing specifications particular to the electric motorization of valves and fittings.
 - HM62/3910 - Qualification testing specifications particular to the electrical.
- N.B.: Both junction types have been tested during qualification testing of the valves and fittings and electrical crossings.
- MODULES AND IN-LINE JUNCTIONS require insulated cables KAPTON-PEEK or EPR.

MONOBLOCK MODULES

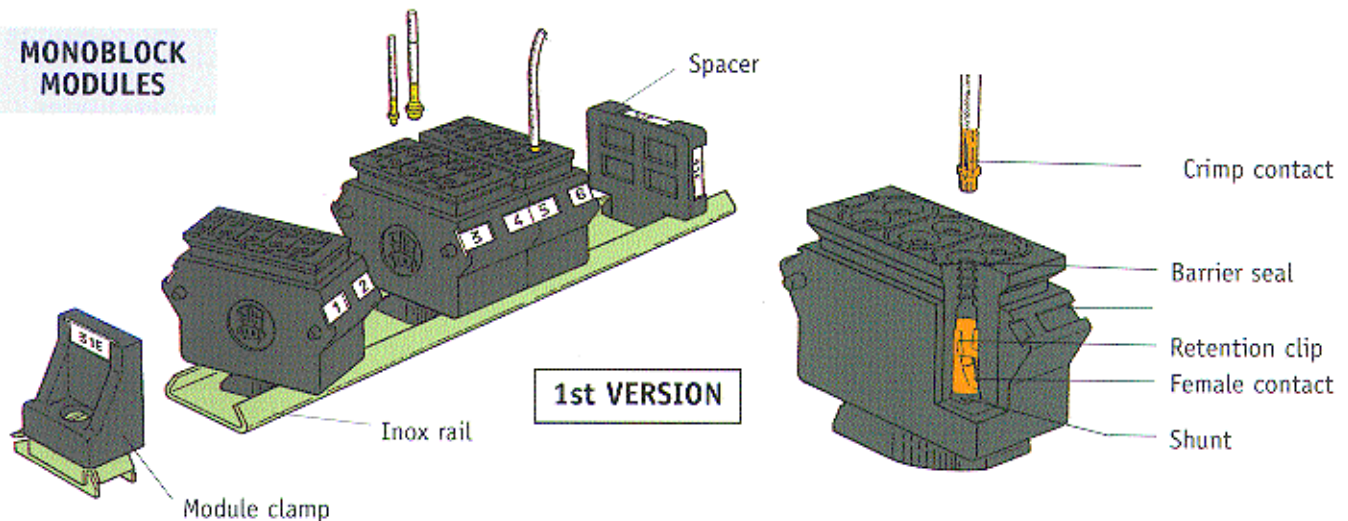

These MODULES have been developed to ensure the interface in the reactor building between the wiring from its core and the control station.

It then becomes imperative to be able to transmit orders, in spite of a severe deterioration of the environment. (APRP or RTV accident).

All conditions are needed to meet these requirements and environmental tests EDF / DER n° HM 63 - 7195/5 concerning 1E-A classified materials for nuclear power stations.

APRP: Accident caused by primary refrigerant loss.

RTV: Vapour pipe rupture.

1E-A Category: Material installed in the enclosure which must function during or after an accident within this enclosure.

NG MODULAR MODULES

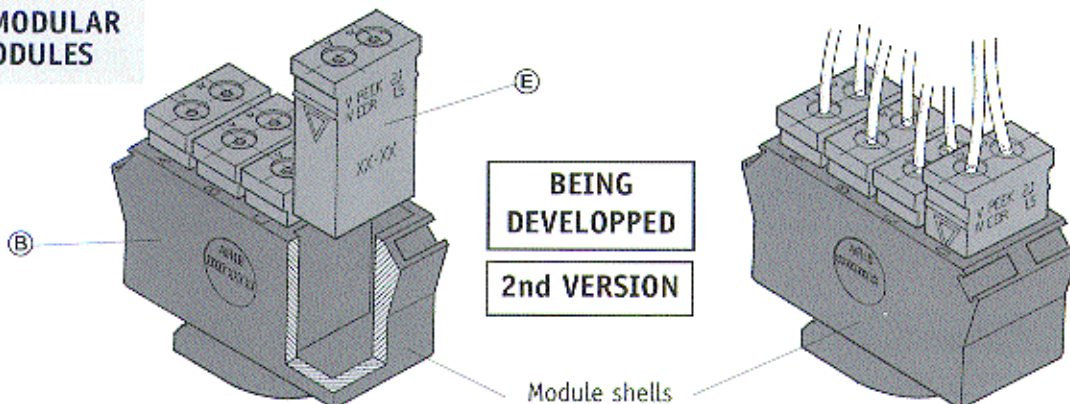

Quick and economical operation and intervention on only one circuit by solely replacing the defective part of module ©. Module © is interchangeable with the first version.



285 Kesmark
Dollard-des-Ormeaux,
Quebec, Canada H9B 3J1
Tel.: (514) 421-2153
Fax: (514) 421-3408
www.air-lb.ca

THROUGH IN-LINE JUNCTIONS

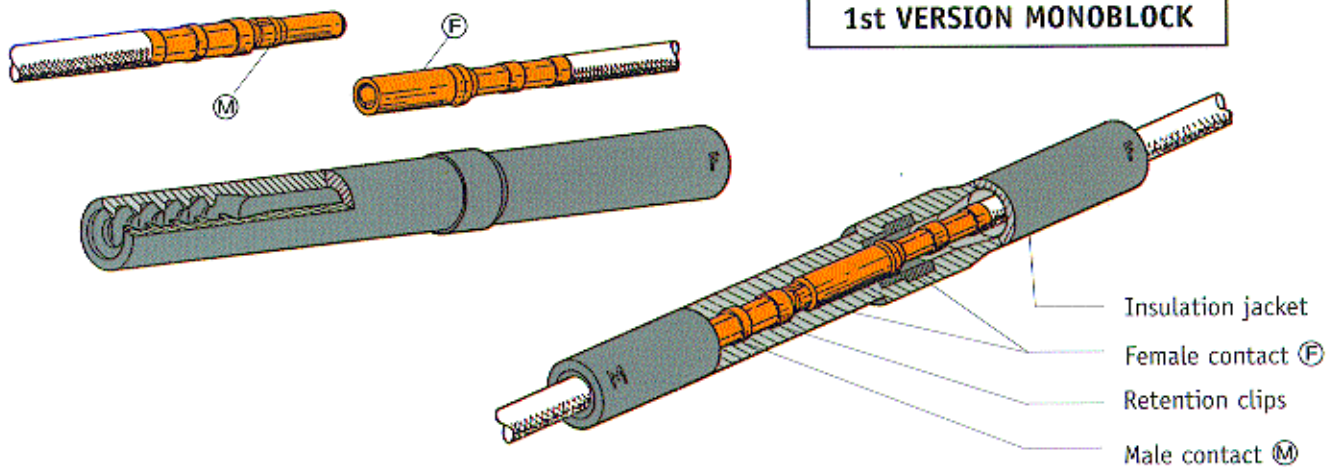

AIR LB THROUGH IN-LINE JUNCTION for nuclear environment are crimp, quick junction, insertion-extraction contact types. This simple junction connector type is for quick, sealed connection of a multi wire core cable from the reactor core with a rigid core cable from outside.

With this crossing, all conditions are required to satisfy:

- normal ageing
- ADR accidents
- EDF/DER n° HM-63 7195/5 environment conditions relative to classified materials 1E-A for PWR power stations.

NG IN-LINE JUNCTIONS M-F COUPLINGS

2nd VERSION - Repairable

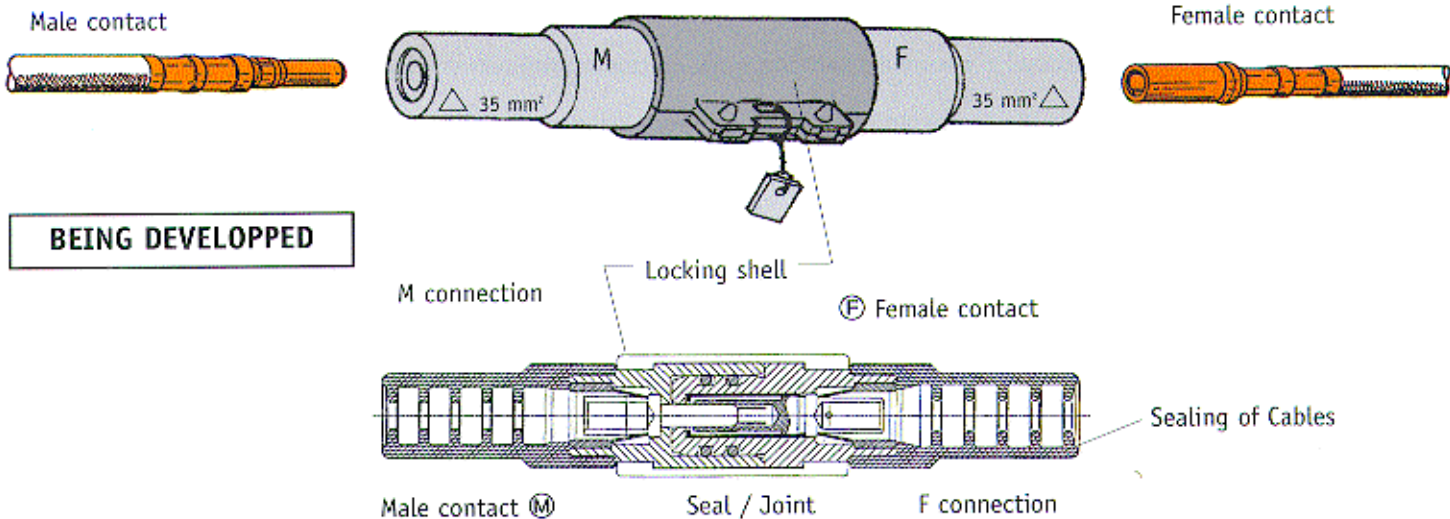

As with MODULAR NG MODULES, operation, disconnection and reconnection of parts M and F are quick and economical.

TECHNICAL DATA

1	MODULE	:	Silicone
	CONTACTS	:	Copper alloy
	PROTECTION	:	Gold plated nickel for thermocouple
	CABLE SECTIONS	:	1 mm ² to 35 mm ²

2	IN-LINE JUNCTION	:	Silicone
	CONTACTS	:	Copper alloy
	PROTECTION	:	Gold plated nickel
	CABLE SECTIONS	:	2,5 mm ² to 8,3 mm ² 16 mm ² to 35 mm ²